



FI0127

**FITTING INSTRUCTIONS FOR FI0127BK FRAME INSERT**  
**KAWASAKI Z650 2017**

Page | 1



**THIS KIT CONTAINS THE ITEMS PICTURED AND LABELLED BELOW.**  
**DO NOT PROCEED UNTIL YOU ARE SURE ALL PARTS ARE PRESENT.**

**Please note that the way the kit is packed does not necessarily represent the way of mounting to the bike**

THE PARTS SHOWN MAY BE REPRESENTATIVE ONLY (FOR CLARITY OF INSTRUCTIONS ONLY)

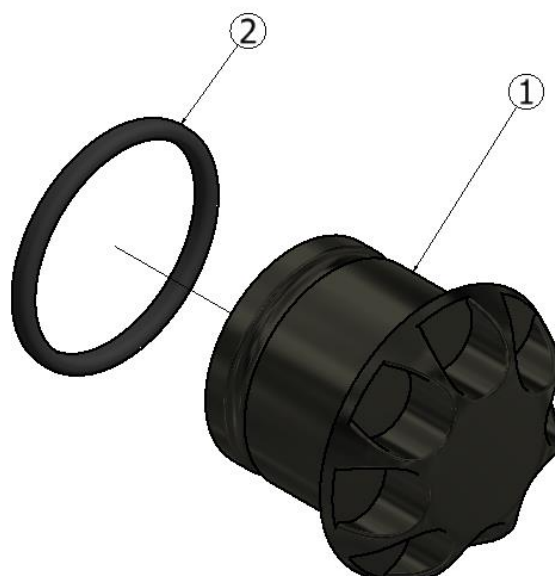

Please note that in cases where kits are packed with rubber washers holding the components onto the bolt – *the rubber washers should be thrown away!*

R&G Racing  
Unit 1, Shelleys Lane, East Worldham, Alton, Hampshire, GU34 3AQ

Tel: +44 (0) 1420 89007 | Fax : +44 (0) 1420 87301 | Email: [info@rg-racing.com](mailto:info@rg-racing.com)



FI0127

### **LEGEND**

- ITEM 1 = R&G Frame Plug (FI0127) (x2)
- ITEM 2 = OEM rubber O-Ring

### **TOOLS REQUIRED**

- Small flat-head screwdriver

Page | 2

### **Left or right-hand side (as you sit on bike)**

- Remove the OEM Frame plug
- Remove the OEM rubber O-Ring from the OEM frame plug using a small flat head screwdriver
- Fit the OEM O-Ring just removed to R&G frame plug
- Locate the R&G frame plug assembly as original
- **Regularly check to ensure frame insert remains tight.**

ISSUE 1 19/04/2017 (HH)

### **CONSUMER NOTICE**

The catalogue description and any exhibition of samples are only broad indications of the Products and R&G may make design changes which do not diminish their performance or visual appeal and supplying them in such state shall conform to the order. The Buyer acknowledges no representation or warranty (other than as to title) has been given or will apply to the Products other than those in R&G's order or confirmation and the Buyer confirms it has chosen the Products as being of merchantable quality and suitable for its particular purposes. Where R&G fits the Products or undertakes other services it shall exercise reasonable skill and care and rectify any fault free of charge unless the workmanship has been disturbed. The Buyer is responsible for ensuring that the warranty on the motorcycle is not affected by the fitting of the Products. On return of any defective Products R&G shall at its option either supply a replacement or refund the purchase money but shall not be liable if the Products have been modified or used or maintained otherwise than in accordance with R&G's or manufacturer's instructions and good engineering practice or if the defect arises from accident or neglect. Other than identified above and subject to R&G not limiting its liability for causing death and personal injury, it shall not be liable for indirect or consequential loss and otherwise its liability shall be limited to the amounts paid by the Buyer for the Products or the fitting or service concerned. These terms do not affect the Buyer's statutory rights.

### **R&G RACING RETURNS POLICY (NON-FAULTY GOODS)**

Returns must be pre-authorized (if not pre-authorized the return will be rejected). Goods may only be returned direct to us if they were purchased direct from us (customer must prove if necessary). Otherwise to be returned to original vendor. Goods must be in re-sellable condition, in the opinion of R&G Racing. All returns are subject to a 25% restocking and handling fee (25% of the gross value exc. P&P – at the prevailing price at time of purchase). The customer must pay any and all carriage charges. No returns of discontinued products, unless within 14 days of purchase. This policy does not affect your statutory rights and does not refer to faulty goods.

R&G Racing

Unit 1, Shelleys Lane, East Worldham, Alton, Hampshire, GU34 3AQ

Tel: +44 (0) 1420 89007 | Fax : +44 (0) 1420 87301 | Email: info@rg-racing.com



FI0127

**NOTICE DE MONTAGE POUR FI0127BK INSERT DE CADRE  
KAWASAKI Z650 2017**

Page | 3



**Le kit contient les articles exposés ci-dessous, vérifier que toutes les pièces soient présentes avant de procéder au montage.**

**La façon dont le kit est emballé ne correspond pas forcément à la façon de monter les pièces sur la moto.**

**LES PARTIES PRESENTEES PEUVENT ETRE UNIQUEMENT REPRESENTATIVES (POUR LA CLARTE DES INSTRUCTIONS UNIQUEMENT)**

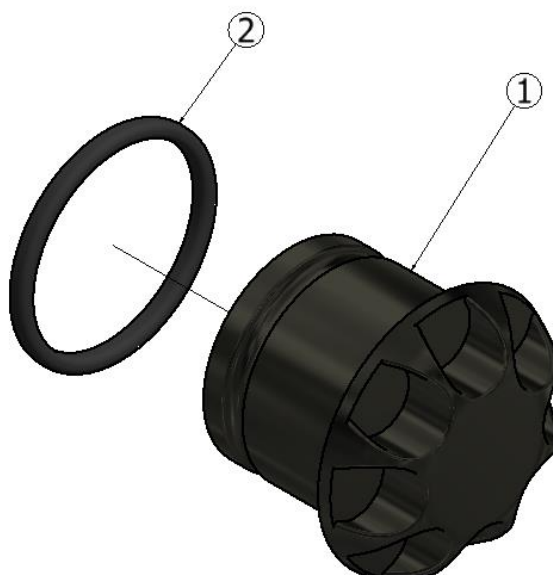

Notez que si les kits sont emballés avec des rondelles en caoutchouc servant à tenir les composants, *ces rondelles doivent être jetées!*



FI0127

### **LEGENDE**

- ARTICLE 1 = Prise de cadre R&G (FI0127) (x2)
- ARTICLE 2 = Bague en caoutchouc d'origine

### **OUTILS REQUIS**

- Petit tournevis plat

Page | 4

### **Coté gauche ou droit (lorsqu'on est assis sur la moto)**

- Enlever la prise de cadre d'origine
- Enlever la bague en caoutchouc d'origine de la prise de cadre d'origine à l'aide d'un tournevis plat.
- Insérer la rondelle d'origine tout juste enlevée de la prise de cadre R&G.
- Placer la prise de cadre R&G comme à l'origine
- **Vérifier le serrage régulièrement pour vous assurer que le l'insert de cadre soit bien en place.**

ISSUE 1 19/04/2017 (HH)

### **CONSUMER NOTICE**

The catalogue description and any exhibition of samples are only broad indications of the Products and R&G may make design changes which do not diminish their performance or visual appeal and supplying them in such state shall conform to the order. The Buyer acknowledges no representation or warranty (other than as to title) has been given or will apply to the Products other than those in R&G's order or confirmation and the Buyer confirms it has chosen the Products as being of merchantable quality and suitable for its particular purposes. Where R&G fits the Products or undertakes other services it shall exercise reasonable skill and care and rectify any fault free of charge unless the workmanship has been disturbed. The Buyer is responsible for ensuring that the warranty on the motorcycle is not affected by the fitting of the Products. On return of any defective Products R&G shall at its option either supply a replacement or refund the purchase money but shall not be liable if the Products have been modified or used or maintained otherwise than in accordance with R&G's or manufacturer's instructions and good engineering practice or if the defect arises from accident or neglect. Other than identified above and subject to R&G not limiting its liability for causing death and personal injury, it shall not be liable for indirect or consequential loss and otherwise its liability shall be limited to the amounts paid by the Buyer for the Products or the fitting or service concerned. These terms do not affect the Buyer's statutory rights.

### **R&G RACING RETURNS POLICY (NON-FAULTY GOODS)**

Returns must be pre-authorized (if not pre-authorized the return will be rejected). Goods may only be returned direct to us if they were purchased direct from us (customer must prove if necessary). Otherwise to be returned to original vendor. Goods must be in re-sellable condition, in the opinion of R&G Racing. All returns are subject to a 25% restocking and handling fee (25% of the gross value exc. P&P – at the prevailing price at time of purchase). The customer must pay any and all carriage charges. No returns of discontinued products, unless within 14 days of purchase. This policy does not affect your statutory rights and does not refer to faulty goods.

R&G Racing

Unit 1, Shelleys Lane, East Worldham, Alton, Hampshire, GU34 3AQ

Tel: +44 (0) 1420 89007 | Fax : +44 (0) 1420 87301 | Email: info@rg-racing.com